

100A Battery Shield

The Ring Battery Shield is the ideal solution to prevent flat batteries and battery failure by over discharging.

Whether the vehicle is fitted solely with the chassis battery, or is fitted with a secondary auxiliary battery, the battery shield is a crucial piece of protective equipment that prevents flat batteries and engine start failure by interrupting power supply to ancillary equipment.

Key functions

- 10 x Programmable settings
- Ease of programme change
- Auto mode selection (12V/24V)
- Connection for remote alarm
- Switch connection remote on/off
- IP65
- Built in heat sink
- Supplied with installation kit and instructions



Typical installation

Single Battery System

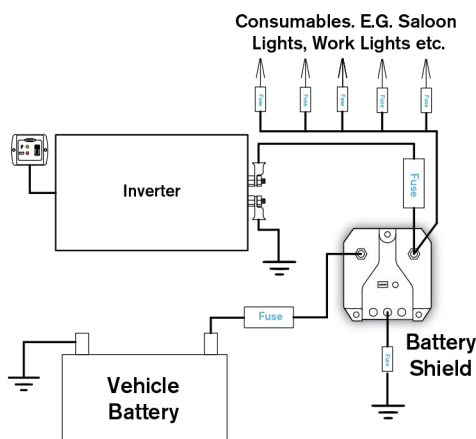

Auxiliary Battery System

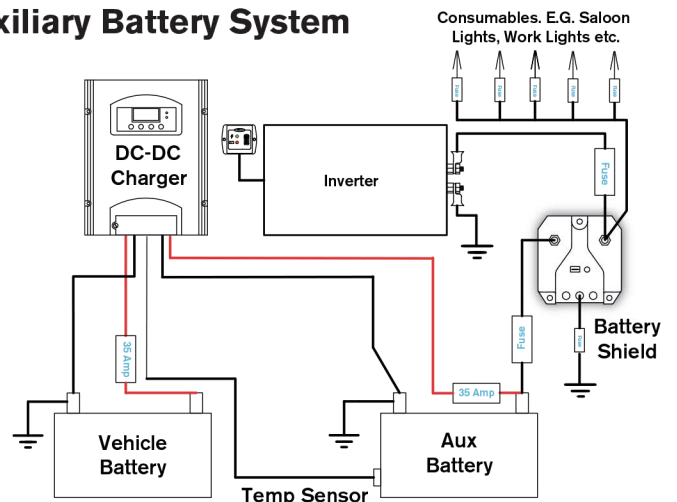

Product Code	RTBS100
Case Quantity	5 x 1
Pack Dimensions	H52 x W127 x D105mm
Packaging	Carton
Barcode	5055175242224